

Manduca sexta Wax Model

Student Name: _____

Collect your supplies.

- 2 long strands (for SEG and brain) : _____ (color)
- 1 long strand (for abdominal section): _____ (color)
- ½ strand (for thoracic section): _____ (color)

Making your own model of a Manduca sexta caterpillar nervous system

Make the length of the nervous system (basically made up of several long axons).

Take two long pieces/strands of wax of the same color. Overlap the ends (at least 1 inch) from both pieces and press on them until it forms one long strand.

Make the Sub Esophageal Ganglia or “SEG” which controls feeding.

1. Break off a ¾ inch piece from one end of the long strand.
2. Wrap that piece tightly around the remaining nervous system about 1 ½ inches from the end.

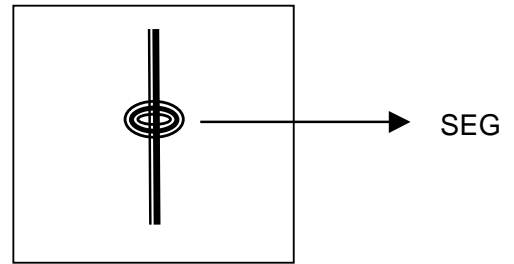

Make the brain!

Take the part above the SEG and fold it so it resembles a “T” shape as in this diagram.

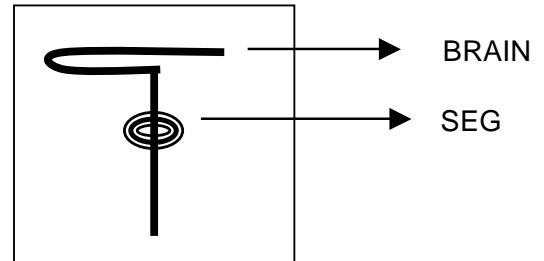

Make the ganglia. (Note: Ganglia is the plural of ganglion.)

Start with the THORACIC ganglia.

1. Get the wax strand/color you chose for the thoracic section.
2. Break the thoracic strand into three pieces (about ¾ in. long)
3. Wrap one of these ¾ inch pieces around the nervous system ¼ inch below the SEG. This is called “T1” (Thoracic 1). Press the ends together or against the strand.
4. Wrap another piece (T2) 1 ½ inches below that and press against the strand.
5. Wrap the third (T3) 1 ½ inches below that and press against the strand.

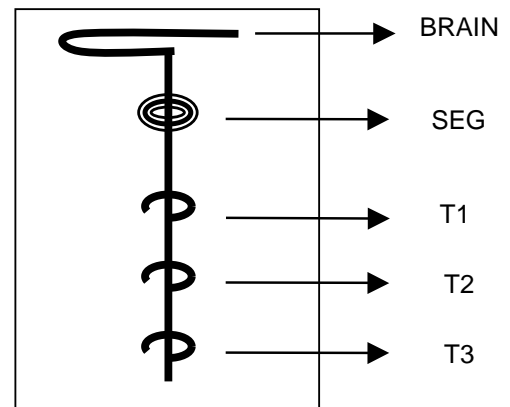

Manduca sexta Wax Model

Student Name: _____

After the thoracic region, make the Abdominal section.

Using the strand/color for the **abdominal** section,

1. Break off 8 pieces that are each $\frac{3}{4}$ inch long.
2. Wrap the first piece (A1) 1 $\frac{1}{4}$ inches below T3.
3. Wrap A2 about 1 $\frac{1}{4}$ inches below A1.
4. Wrap A3 about 1 $\frac{1}{4}$ inches below A2.
5. Wrap A4, A5, A6, and A7 each about 1 $\frac{1}{4}$ inches below the one before it.
6. Wrap A8 below A7 so both pieces touch each other.
7. Break off any remaining part of the long strand that sticks out beyond A8.

You have just made a model of the nervous system of the *Manduca sexta*!!

Let's think about the *Manduca sexta* nervous system...

- The wax strand used to make the brain represents the *axons*.
- The round bumps of different colors represent the *ganglia* which are made out of cell bodies.
- The ganglia have several axons that connect to different neurons.

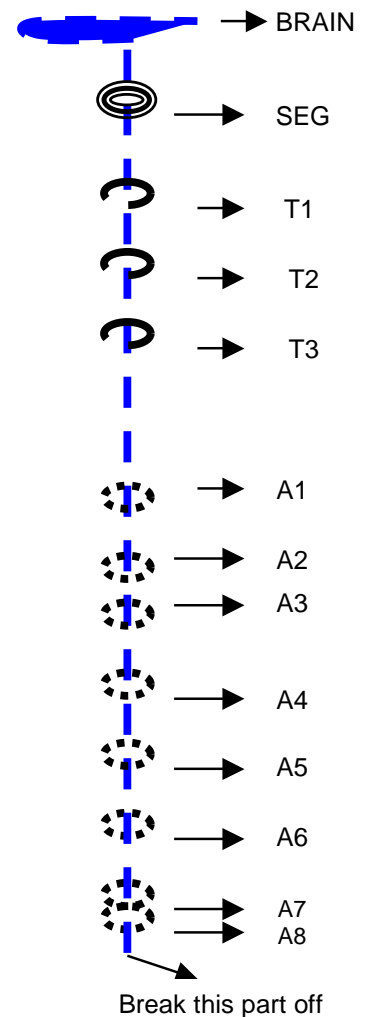

NOW, let's go through METAMORPHOSIS!

Metamorphosis means to transform. You will now take your model *Manduca* through metamorphosis. Here are the steps:

1. Using your thumb and forefinger, **SQUEEZE and flatten** the SEG and brain section. Slowly stretch the flattened SEG and brain section so it will increase in size. There will be NO SEG section left.

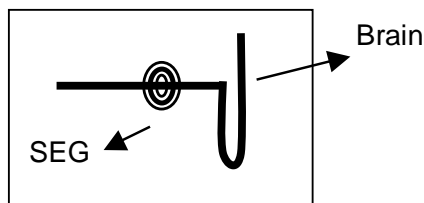

From this model

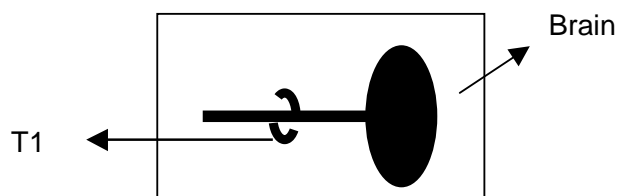

To this model with no SEG

Manduca sexta Wax Model

Student Name: _____

2. Make loops between T1-T2, T2-T3, T3-A1, A1-A2, A6-A7, and A7-A8.

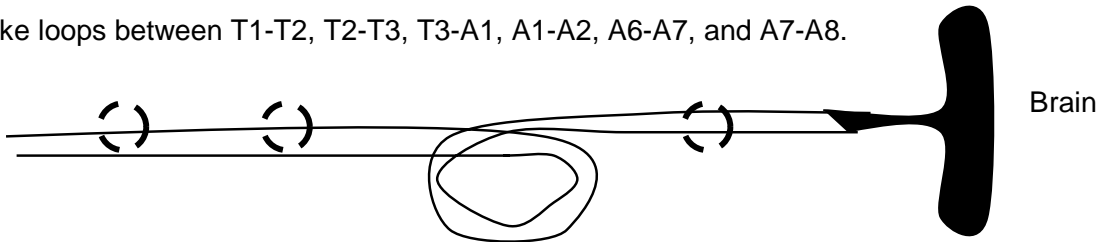

3. Pinch off the loop. You can also twist the loop off.

You have now made the metamorphosed moth.

Now, what did we learn? Let's see . . .

- A. Compare the nervous system of the caterpillar and the metamorphosed moth. Write down all similarities and differences you notice.

	Caterpillar	Moth
Similarities		
Differences		

- B. Look at the picture of the metamorphosed moth in your diagrams from earlier this hour. Do you see any loops? _____

What do you think happened to them?

- C. With your partner, tape your models onto a big sheet of paper and label the following:
- Which model is the moth and which is the caterpillar
 - The brain, SEG, and each ganglia on both models
 - An example of where each of the following would be found: Cell bodies, Dendrites, Axons

- D. For your notebooks, do two things:
- DRAW the models with colored pencils or crayons, then LABEL everything as you did on your model sheet.
 - DRAW and/or WRITE the differences in behavior, shape, and neural structure between the juvenile and adult *Manducas*.